

“High Availability Hoot’n’Holler Bridge Products”

Reasons to purchase

- ❑ "Our Team has over a decade of experience in the design and implementation of Global Hoot'n'Holler networks".
- ❑ "By specifying a Miton Bridge at the core of your business-critical Hoot'n'Holler systems, you gain access to world-class expertise in these critical systems which is independent of desktop equipment and network providers.
- ❑ We know how to design and maintain mission-critical systems with minimum fuss and involvement
- ❑ A dedicated design - not an adaptation
- ❑ Very Low latency static bridge
- ❑ Low-risk granular architecture - free from "big bang" failures
- ❑ Module-level spares strategy - ideal for remote deployment in inaccessible emerging markets
- ❑ Backed with Independent World-class voice expertise at the core of your H&H network

Description

- ❑ Miton Hoot'n'Holler bridges are custom designed around a unique granular architecture designed for maximum availability and performance. Our distributed architecture supports various levels of redundancy to suit your application and budget.
- ❑ Miton Bridges use a distributed conference architecture, allowing parts of the bridge to be upgraded or exchanged without needing to take the whole bridge (and a large chunk of your Hoot'n'Holler network) out of service. Gone are the days where a single point failure can take out your entire Hoot'n'Holler network in one go!
- ❑ Miton's Voice over Ethernet technology (MVoE) is a key enabling technology allowing bridges to be configured which are scalable and resilient whilst maintaining exceptionally low latency. Using Ethernet as a backbone, we are able to integrate complex dial-in call processing with business-critical Hoot'n'Holler services but without the headache and vulnerability of placing both services on the same physical chassis.
- ❑ Miton Hoot'n'Holler Bridges are made from similar, modular components interconnected using Ethernet. Each module in the Bridge can be quickly replaced with a spare in the event of failure, offering significant advantages in the cost of maintaining a realistic spares strategy. Hitherto you only had the option of a complete replacement bridge (expensive) or card-level spares (you can never be certain they will work until placed into service). By contrast, Miton bridges require only one standard component as a standby

replacement which can be kept running continuously to prove its continued health.

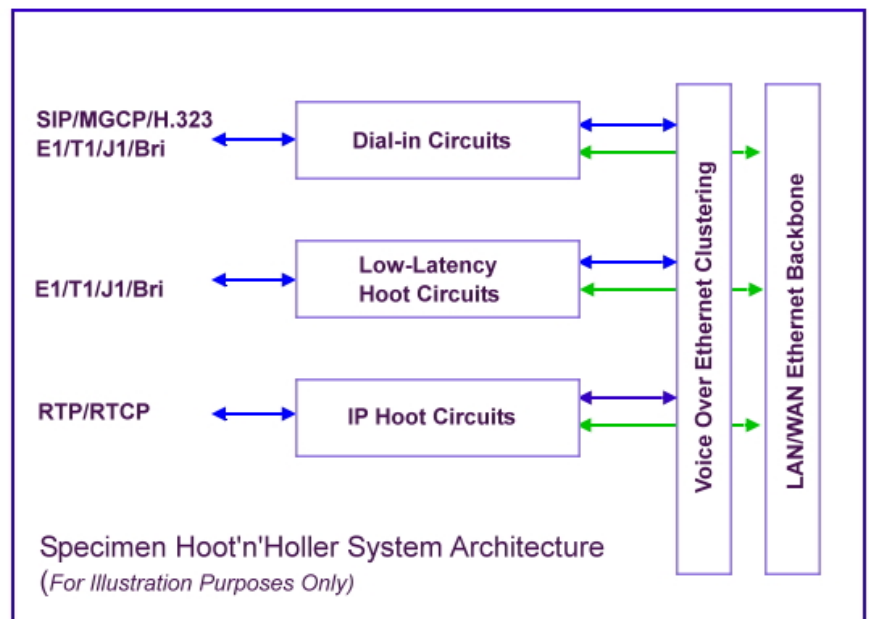

- ❑ Miton Hoot'n'Holler bridges are the result of a technology collaboration with our Alliance partners in the Finance Industry, Tecbridge Ltd. Tecbridge brings world-class expertise in design and deployment of global Hoot'n'Holler systems to the party.

Support

- ❑ Hoot'n'Holler bridges lie at the cross-roads of prominent business critical voice systems. Banks will want to be assured they can rely on the help and support of this key component if technical issues emerge which impact the performance of the Hoot'n'Holler system as a whole. We cannot fix

problems within third party systems and networks, but we can help Banks identify and address issues with specialist independent technical expertise in Hoot'n'Holler systems not normally available to Banks.

- ❑ Working with Tecbridge Ltd, our Alliance partners in Finance, Miton are able to back our Hoot'n'Holler bridges with proven expertise in the design and deployment of Global Hoot'n'Holler systems.

System Features

- ❑ Linux O/S
- ❑ Distributed granular architecture
- ❑ Fully Scaleable
- ❑ VOIP/TDM/Analog interfaces available
- ❑ Very low latency
- ❑ Economic but comprehensive spares strategy
- ❑ SNMP - includes Bridge health + network status
- ❑ Browser based management tools
- ❑ Backed with World-Class support and exp

Specification Overview

Hardware



- ❑ Voltage (240/110v)
- ❑ Dual Redundant, Dual feed Power Supplies
- ❑ Rack Mount 1U/2U Industrial spec PC
- ❑ Single or Dual Processor depending on capacity
- ❑ Up to 120 channels per chassis with E1/T1 Card
- ❑ Bridge Clustering technology for larger systems
- ❑ Fan failure
- ❑ Mirrored Disk Array
- ❑ Hardware monitoring (option)
- ❑ CD-ROM
- ❑ 100MB/sec Ethernet port

Software

- ❑ Linux Operating System
- ❑ MySQL Dabase
- ❑ Access software to other databases
- ❑ Apache Web Server
- ❑ System event logging system
- ❑ SIP Connectivity (Option)
- ❑ Firewall software

Voice Over Ethernet Backbone

- ❑ Type Proprietary Voice over Ethernet
- ❑ Medium 1000/100 BaseT Ethernet
- ❑ Options Dual Redundant
- ❑ Capacity 2000+ Concurrent conferences/Channels

Manufacturer



Miton Systems Ltd.,
49 Dove Park, Chorleywood, Hertfordshire, London England.
Tel: +44 (0) 1923 286501 Fax: +44(0) 1923 286498
info@miton.co.uk www.miton.co.uk

All Trademarks are the property of their respective owners. © Copyright Miton Systems Ltd 2006

Manufacturers Representative - Global Finance Markets



Tecbridge Ltd.,
400 Thames Valley Park Reading RG6 1PT, UK
Tel: +44 (0) 118 965 3423 Fax: + 44 (0) 118 965 3523
info@tecbridge.co.uk www.tecbridge.co.uk